

NU2135 I²C Controlled Single Cell High Efficiency 9-A Switched Cap Fast Charger

1 Feature

- 98.0% Efficient at 2:1 charge mode, 99.1% Efficient at 1:1 charge mode
- Switched Cap Architecture Optimized for 50% Duty Cycle.
 - Input Voltage is 2x Battery Voltage (2.5V to 5.5V)
 - Output Current is 2x of Input Current (Up to 4.5A)
 - Reduces Power Loss Across the Cable
- Support charge pump 2:1 and 1:1 charge mode
- Support reverse 1:2/1:1 mode
- Integrated Programmable Protection Features for Safe Operation
 - Input Over-Voltage with External OVP FET
 - Input Over-Voltage Protection (BUS_OVP)
 - Input Over-Current Protection (BUS_OCP)
 - Input Under-Current Protection (BUS_UCP)
 - Battery Over-Voltage Protection (BAT_OVP)
 - Output Over-Voltage Protection (OUT_OVP)
 - IBAT Over-Current Protection (BAT_OCP)
- Programmable Settings for System Optimization
 - STAT, FLAG, and MASK options for Interrupts
 - ADC Readings and Configuration
- Integrated 15-Bit Analog-to-Digital Converter (ADC)
 - ±1% BUS Voltage
 - ±5% BUS current at 2.5A (0°C to 85°C)
 - ±1% VOUT Voltage
 - ±0.5% BAT voltage with Differential Sensing at VBAT=4.44V(0°C to 85°C)
 - ±5% BAT Current at 5A with External R_{SENSE}=2mΩ(-20°C to 85°C)
 - ±4°C Die Temperature

- Tablet PC

3 Descriptions

NU2135 is a 98.0% efficient, 9-A battery charging solution using a switched cap architecture. This architecture and the integrated FETs are optimized to enable a 50% duty cycle, allowing the cable current to be half the current delivered to the battery, reducing the losses over the charging cable as well as limiting the temperature rise in the application. The dual-phase architecture reduces the input cap requirements as well as reducing the output voltage ripple.

Device Information

PART NUMBER	PACKAGE	BODY SIZE (mm)
NU2135	WLCSP-35	2.45x2.45

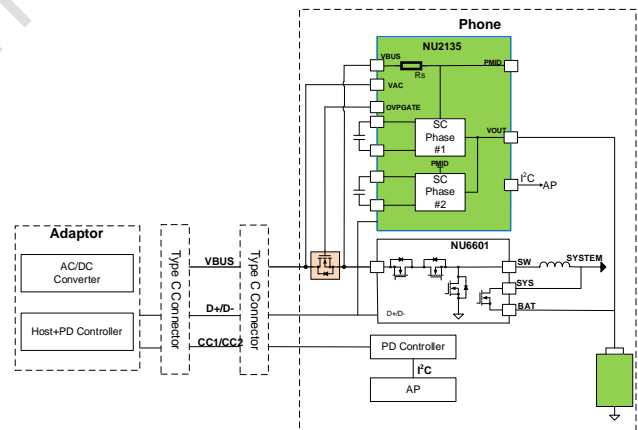

Figure 1. Simplified Application Diagram

2 Applications

- Smart Phone

This document contains confidential and proprietary information of NuVolta. Any information in this document is prohibited from being used, reproduced or disseminated to any third party in any form and/or through any means without the prior written consent of NuVolta. **ALL RIGHTS RESERVED.**